

Castor D125 swivel with double-brake, heavy-duty-8

Product number ZI-1541

Weight 3.3kg

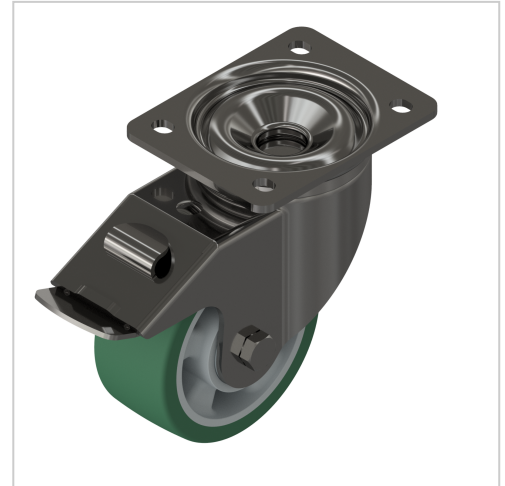

Product description

Swivel and fixed castors are used on assemblies and frames of all kinds. They have very good rolling characteristics and are highly resilient. The castors are resistant to many environmental influences. Especially for use in electrical production, many castors are also available in ESD versions. The ESD version has a discharge resistance of 110 Ohm.

Product properties

Roll type	Swivel castor with double brakes
Mounting type	Screw-on plate
Compatible with	item
Part type	Apparatus castors
Roller diameter	Ø 125 mm
Load capacity	450 kg
Series	Series 8

More images

