

Castor D100 swivel with double-brake plug-in Pin, bright zinc-plated

Product number M-113

Weight 0.7kg

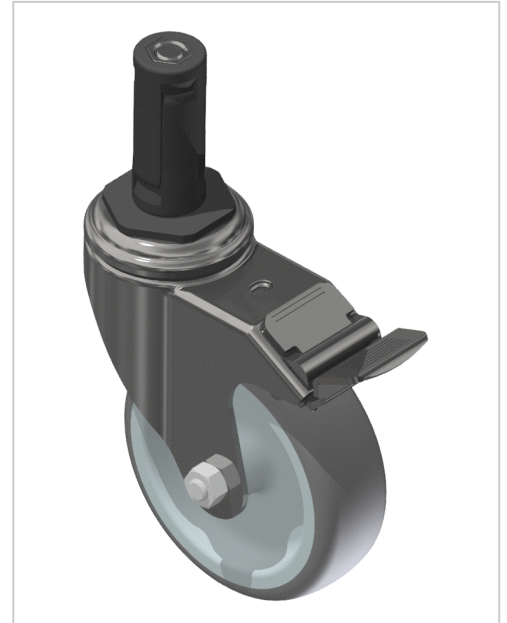

Product description

Swivel and fixed castors are used on assemblies and frames of all kinds. They have very good rolling characteristics and are highly resilient. The castors are resistant to many environmental influences.

Product properties

Roll type	Swivel castor with double brakes
Mounting type	Tenon
Compatible with	Beewatec
Series	S- LPS Lean Production
Part type	Apparatus castors
Roller diameter	Ø 100 mm
Lean system type	D28 steel kit system
Load capacity	110 kg

More images

